

# Introduction to Accelerators

## Outline:

1. Accelerators - from discovery machines to everyday tool
2. Electrostatic (DC) Linear Accelerator
3. RF Field Linear Accelerator
4. Circular accelerators: cyclotron & betatron
5. Circular accelerators: synchrotron
6. Beam optics and particle tracing
7. Transverse beam dynamics: betatron oscillations
8. Synchrotron radiation
9. Colliders and luminosity
10. Limits for future high-energy colliders

References: F. Hinterberger: Physik der Teilchenbeschleuniger und Ionenoptik  
(selection) K. Wille, Physik der Teilchenbeschleuniger und Synchr.strahl. <sup>1</sup>  
[www.classe.cornell.edu/~liepe/webpage/education4456.html](http://www.classe.cornell.edu/~liepe/webpage/education4456.html)

# 1. Accelerators: From discovery machines to everyday tool

Progress in experimental Particle Physics strongly driven by the progress in accelerator physics: Higher energy and higher beam currents allowed discoveries.

Selection of machines enabling discoveries:

## e-accelerators

Year	Energy	Name / Laboratoy	Physics
1951	22 MeV	Betatron / Illinois	Electron Nucleus scattering
1953	225 MeV	Linac /Stanford	Nucleus form factors
1955	500 MeV	Linac Stanford	Proton form factor
1966	20 GeV	2 miles Linac / Stanford	Partons & Scaling

## e<sup>+</sup>e<sup>-</sup> colliders

1961	225 MeV	AdA / Frascati	1 <sup>st</sup> particle-antiparticle collider
1972	4 GeV	SPEAR / Stanford	$\psi$ -Meson, $\tau$
1978	46 GeV	PETRA / DESY	Gluon
1989	100 GeV	LEP / CERN	Precision Z and W parameter

p/A-accelerators    A = ion

Year	Energy	Name / Laboratoy	Physics
1953	3.3 GeV	Cosmotron / BNL	Kaon & meson production
1955	6.2 GeV	Bevatron / Berkley (weak)	Antiproton
1960	30 GeV	AGS / BNL (strong focus)	CPV, $\Omega$ , $J/\psi$ , Muon neutrino
1976	570 GeV	SPS / CERN	See SppS

pp ( $p\bar{p}$ ) AA colliders

1983	540 GeV	ppbar: SppS / CERN	W, Z Boson
1986	1.8 TeV	ppbar: Tevatron / Femilab	Top
2009	13.6 TeV	LHC / CERN	Higgs

Everyday tool: In 2016 - 30000 accelerators world wide<sup>1)2)</sup>

1% research w/ energy >1GeV      44% are for radiotherapy  
 41% for ion implantation              9% for industrial process  
 4 % for biomedical and other low-energy research

1) <http://www.acceleratorsamerica.org/>

2) T. Feder, *Physics Today* **63** (2) . (2010).



## 2. Electrostatic (DC) Linear Accelerator

Idea: Use E-field of very high-voltage to accelerate particles.

e.g. Cockcroft-Walton accelerators (still used as injectors), van de Graaff accel.

### Van de Graaff accelerator:

1930 v. d. Graaff builds 1<sup>st</sup>  
1.5 MeV voltage generator.

High voltage resistance  
improved if generator and  
acceleration structure are  
inside a pressured vessel  
filled with inert gas  
(SF<sub>6</sub>, N<sub>2</sub> (80)CO<sub>2</sub> (20)).  
In air, discharge limit at  
~100kV/cm ( $E \sim U/r$ )

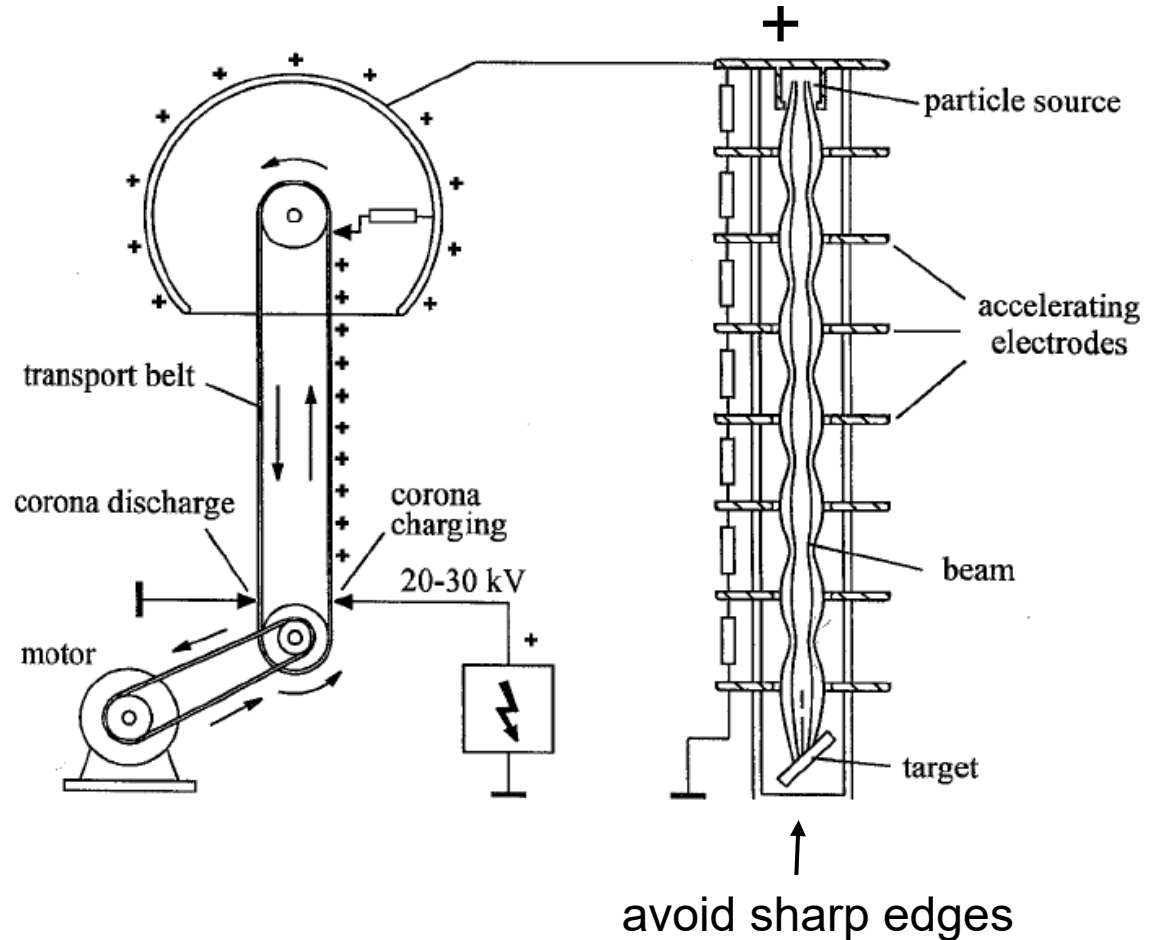

Accelerator tube evacuated ( $< 10^{-6}$  mbar):

Secondary electrons from rest gas leads to additional current and  
when the electrons hit the positive electrodes to emission of x-rays

## Tandem-van-de-Graaff accelerator:

Accelerating voltage is used two times by recharging the particles.

Step 1: negative ions (-e) accelerated to HV electrode

Step 2: charge transfer by stripping off electrons

Step 3: positive ions (+qe) are accelerated towards end

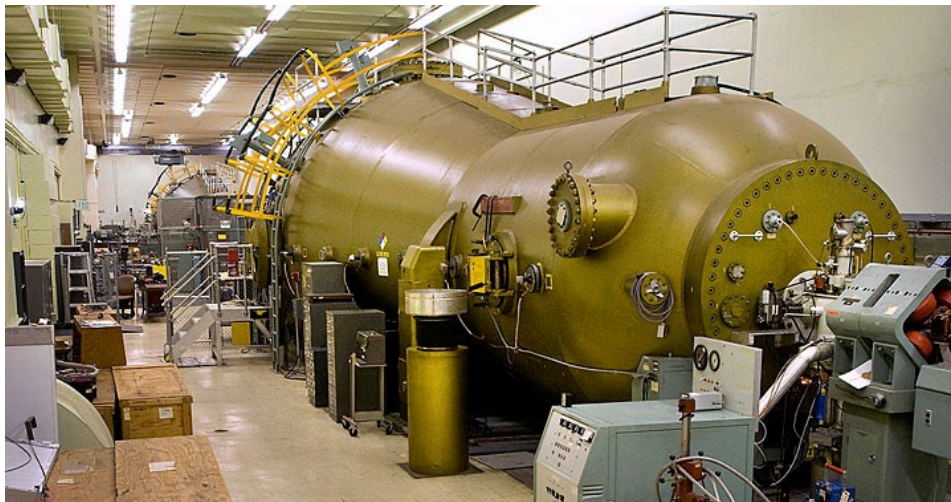
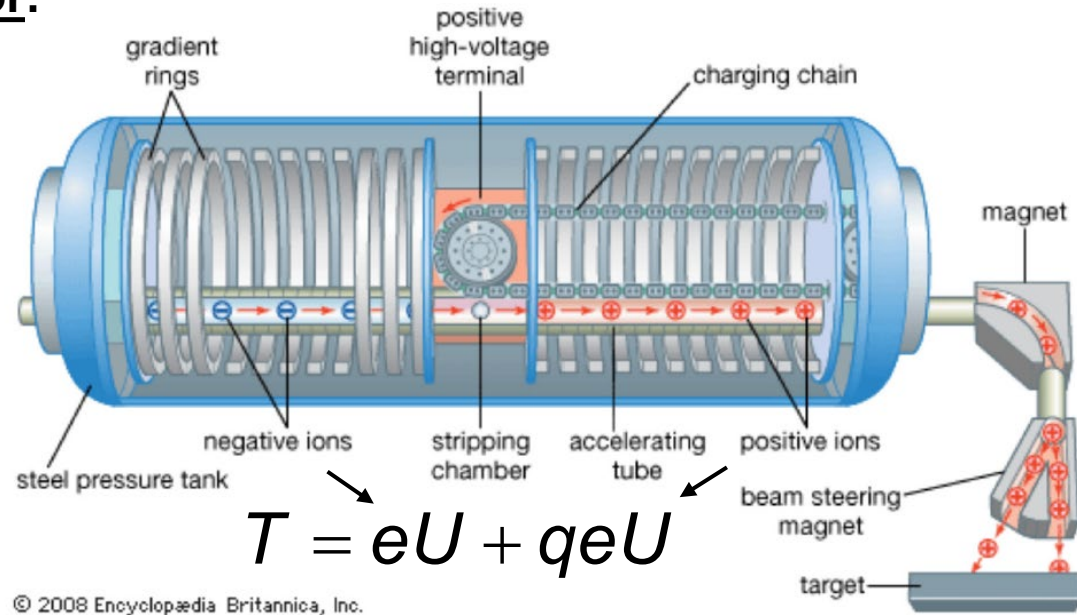

Depending on the ion species, large kin. Energies  $T$  can be reached.

Study of nuclear reaction with very high energy resolution.

Tandem v. d. Graaff at MPI-Kernphysik

BNL tandem v.d.Graaff accelerator:  
Max. terminal voltage of 15 MV

### 3. Radio-frequency (RF) Linear Accelerator

RF linear accelerator (= LINear ACcelerator = LINAC):  
Particle acceleration using an AC voltage.

LINAC:  
used only for RF  
linear accelerators

Wideröe linear accelerator: 1927, progenitor of high-energy accelerators

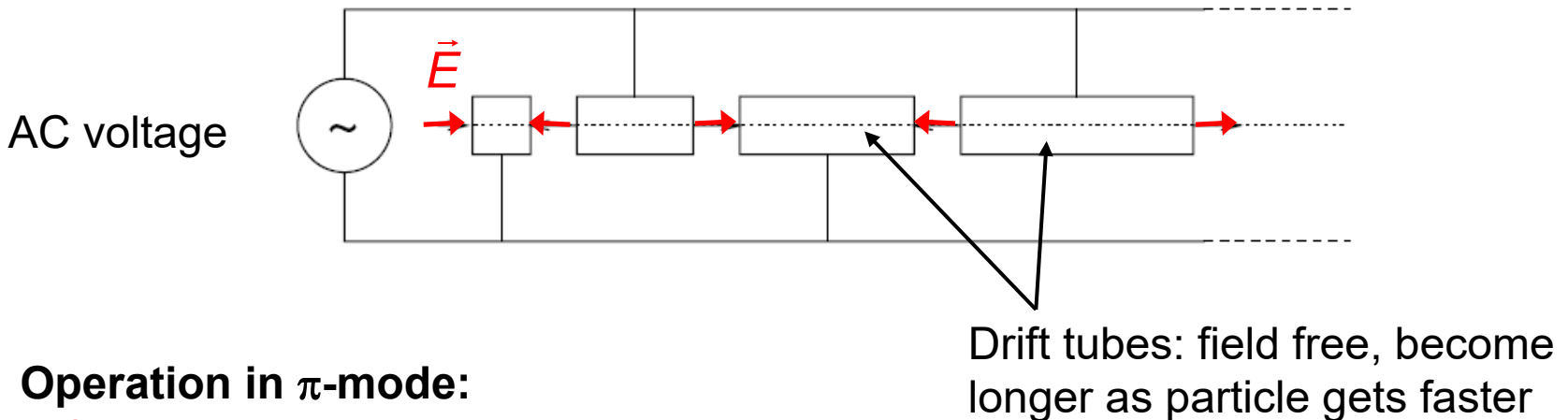

#### Operation in $\pi$ -mode:

**E-field** in neighboring acceleration gaps  
has opposite sign: phase difference =  $\pi$

Important development towards powerful accelerators:

**Klystron** (1937): vacuum tube used for power amplification of RF signals  
(micro wave)

For the acceleration of electrons, protons and ions;  
 depending on the velocity  $\beta$  different RF-accelerating structure are used:

- |                        |                              |                 |
|------------------------|------------------------------|-----------------|
| 1. Wideröe structure:  | $\beta \approx 0.005 - 0.05$ | } Protons, ions |
| 2. RFQ structure:      | $\beta \approx 0.005 - 0.05$ |                 |
| 3. Single RF-cavity:   | $\beta \approx 0.04 - 0.2$   |                 |
| 4. Alvarez-structure:  | $\beta \approx 0.04 - 0.6$   |                 |
| <b>5. RF cavities:</b> | $\beta \approx 1$            |                 |
- ← electrons

(already relativistic at very moderate energies)

Alvarez-Structure:

Series of coupled oscillator cavities w/ drift-tubes.

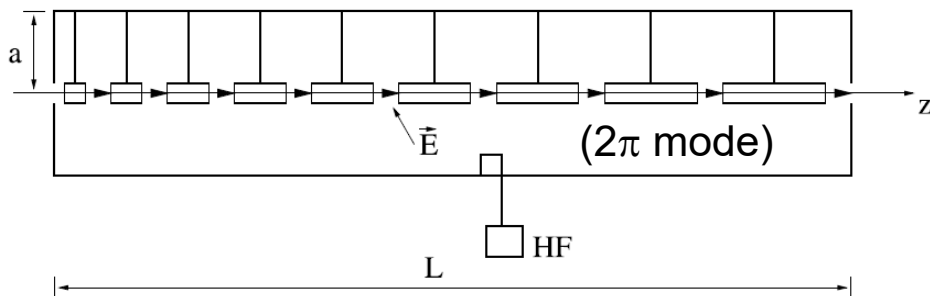

RF cavities:

Travelling or standing wave.

Mostly used today, will be discussed here.

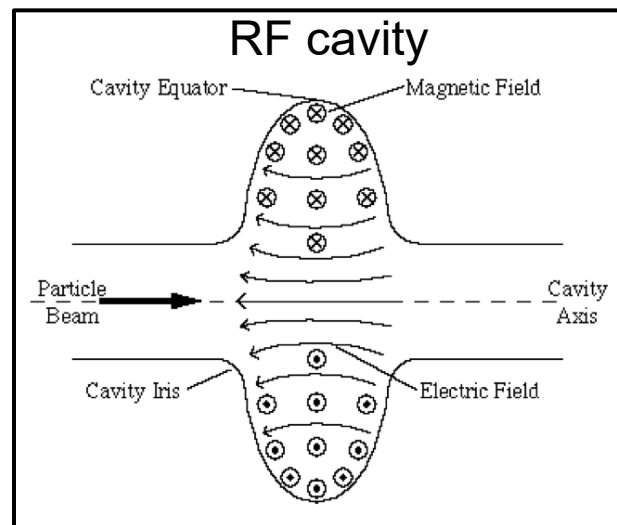

# RF cavities: Travelling or standing wave accelerating structures

Energy win of particle travelling with the electromagnetic wave:  $v = v_\varphi = \frac{\omega}{k}$   
 phase velocity

Particle “surfs” on the e.m. wave:

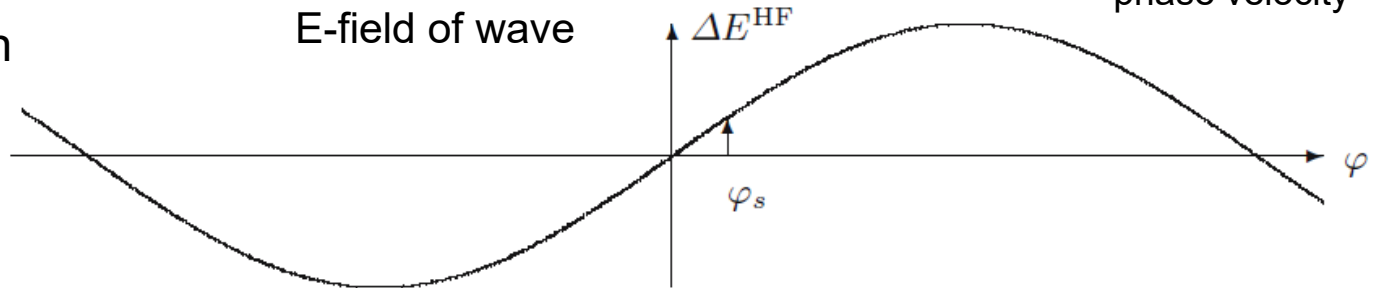

Energy win given by the phase  $\varphi_s$  of the particle:

$$\Delta E^{\text{HF}} = qU_0 \sin \varphi$$

## Phase focusing: (Veksler, McMillian, 1945)

Non-relativistic particles:

Particle too fast w/r to “stable” particle:  
 It arrives earlier and will see less volts.

Particle too slow w/r to “stable” particle:  
 It arrives later and will see higher volts.

Phase focusing will keep particles together:  
 → oscillation around stable phase.

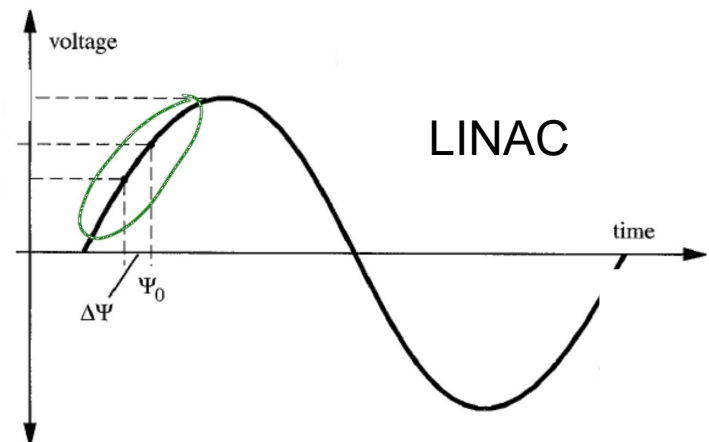



# E.m. wave inside an RF cavity and its phase velocity:

Travelling wave inside a wave guide:

→ need to solve the wave equation w/ boundary conditions

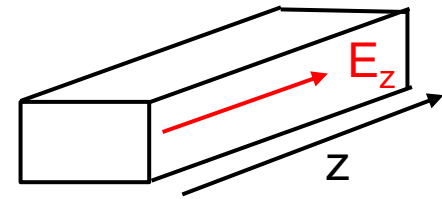

free e.m. wave:  $k = \frac{\omega}{c}$     In cavity:  $k' = \sqrt{k_z^2 + k_c^2}$     and     $\omega > \omega_c$  (otherwise damping)

→ different solutions w/ different transverse modes defined by geometry

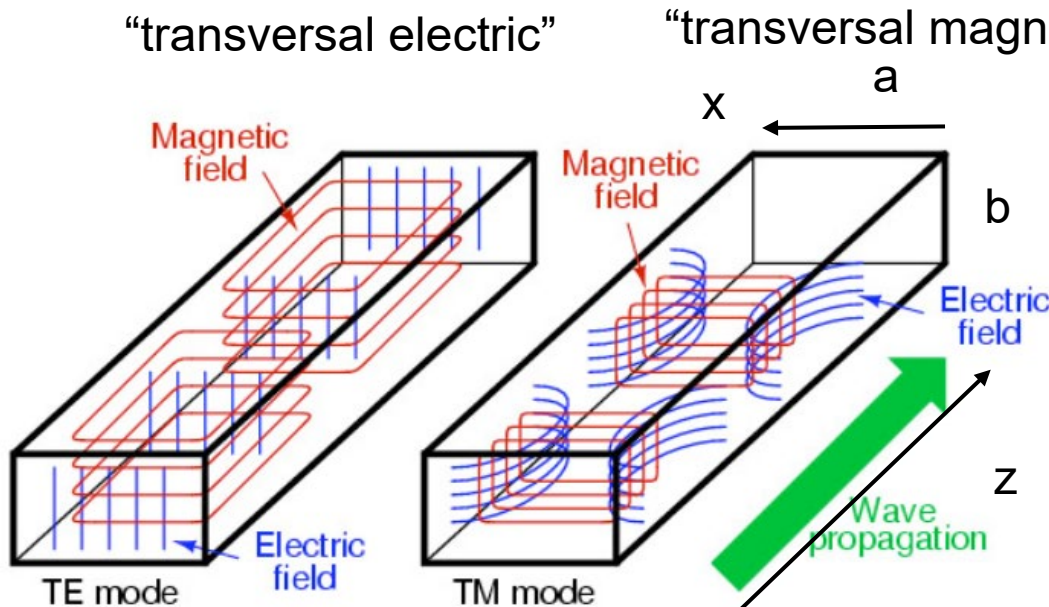

*Magnetic flux lines appear as continuous loops*  
*Electric flux lines appear with beginning and end points*

**TX<sub>mn</sub> mode**

$$k_x a = m\pi$$

$$k_y b = n\pi$$

$$k_c^2 = k_x^2 + k_y^2$$

$$k_c^2 = \left(\frac{m\pi}{a}\right)^2 + \left(\frac{n\pi}{b}\right)^2$$

cavities: **TM<sub>01</sub> mode**  
 (electrical field in z)

Problem:

phase velocity  $v_\phi > c$  for propagation in z  
→ cannot be used for particle acceleration.

$$\text{Dispersion relation: } \omega = c\sqrt{k_z^2 + k_c^2}$$

$$\rightarrow v_\phi = \frac{\omega}{k_z} = c \frac{1}{\sqrt{1 - k_c^2/k'^2}}$$

### Solution: iris aperture

(disk loaded wave guide: Runzelröhre ☺)

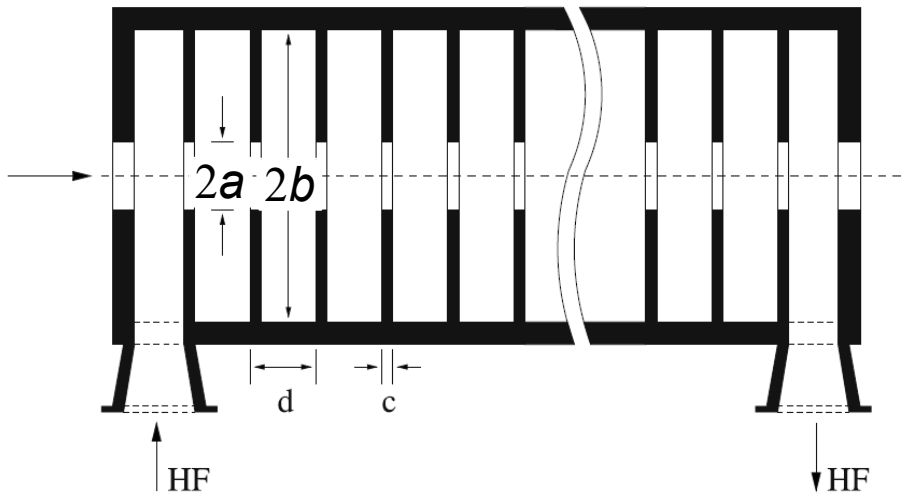

Cavity iris aperture: SLAC structure (Stanford)  
Copper cavity w/  $2b=8.4$  cm,  $2a=2.6$  cm,  $d=3.5$  cm =  $\lambda/3$ ,  $c=0.58$  cm,  $L=3.05$  m,  $\nu=2.856$  GHz  
(travelling wave cavity)

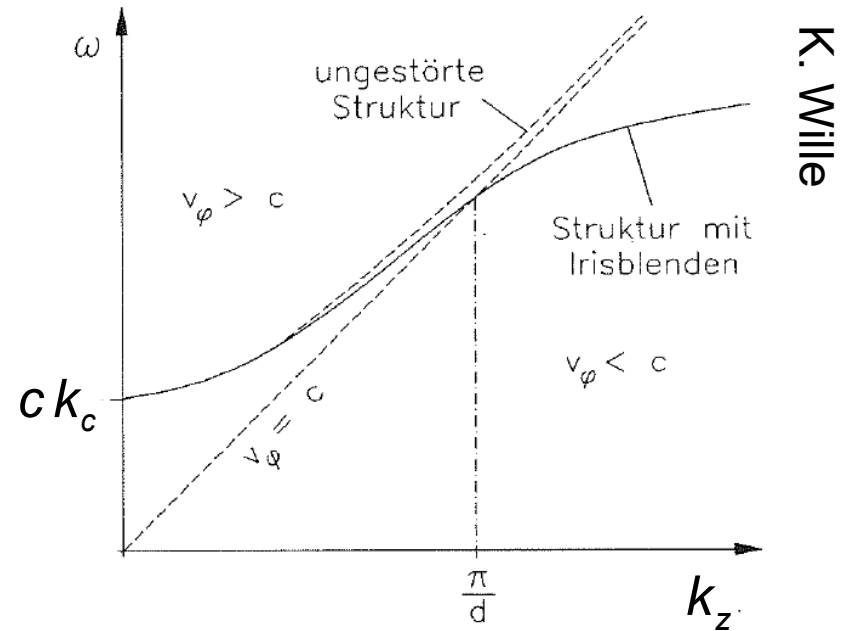

K. Wille

Cavities are build as travelling wave and as standing wave cavities  
(today mostly standing wave cavities used).

# Modern RF cavities: 2 examples

## SUPERCONDUCTING CAVITY WITH ITS CRYOSTAT

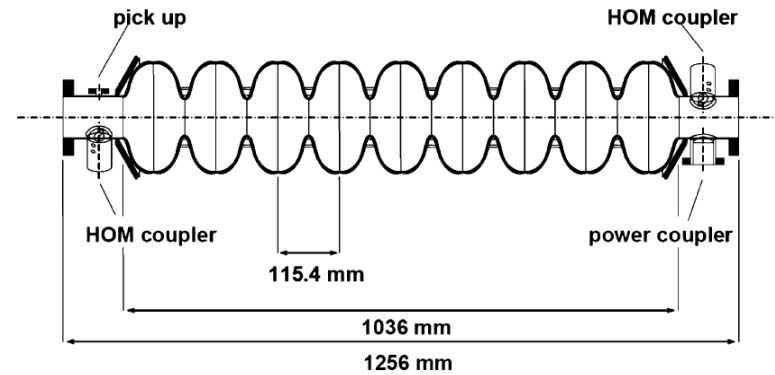
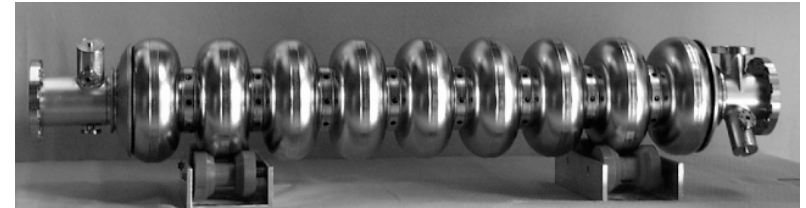
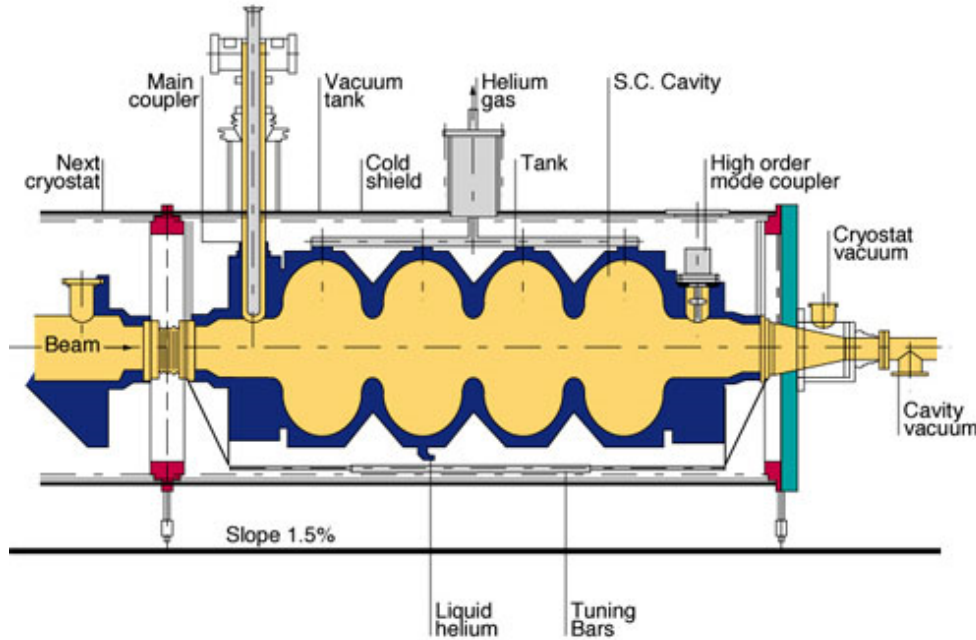

**LHC cavity** (8 per beam):  
Superconductive, gradient of 5.5 MV/m,  
 $\nu=400.8$  MHz.

**ILC / TESLA test cavity** :  
Superconductive, gradient of 32 MV/m

## 4. Circular accelerators: Cyclotron & Betatron (not discussed)

### Classical cyclotron

(Constant B field)

1930 idea by E.O. Lawrence, 1<sup>st</sup> realization: M.S Livingston  
1931 1<sup>st</sup> cyclotron in Berkeley by Lawrence and Livingston  
(protons at T=1.2 MeV)

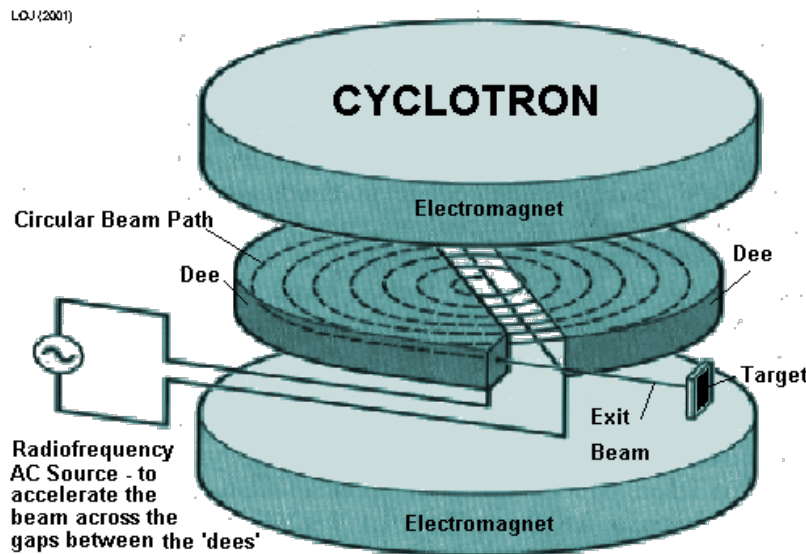

Frequency of applied electrical field ( $O(10\text{kV})$ ) should be equal to cyclotron frequency:

$$\omega_{cycl} = \frac{q}{m} B$$

= typically 5 – 20 MHz for  $B=1\text{T}$ :  
Protons: 15.2 MHz  
Deuterons: 7.6 MHz

large energies with **only few (50) turns**

Energy gain depends on the phase:  
For max. acceleration close to 0.

Problems:

- Relativistic mass increase
- Field gradient (weakening at outside, next slide) necessary for axial stability. → particle phase shifts towards  $+90^\circ$  (no effective RF field)

## Radial and axial stability:

Classical cyclotron needs  
field gradient



Effective Lorentz force:  
Particles **outside the middle  
plane** experience a focusing force  
→ **axial focusing**

### **Radial focusing:**

Effective force as difference between Lorentz force and centripetal force

→ Radial field gradient necessary for axial focusing should not be too large:

$$\text{field index } n \quad n = -\frac{\partial B}{\partial r} \frac{r}{B} \quad \text{Classical cyclotron} \quad n \leq 0.15$$

→ axial and radial oscillations: **“betatron oscillations”**:

Theory developed for betatrons, oscillation are important for synchrotrons.

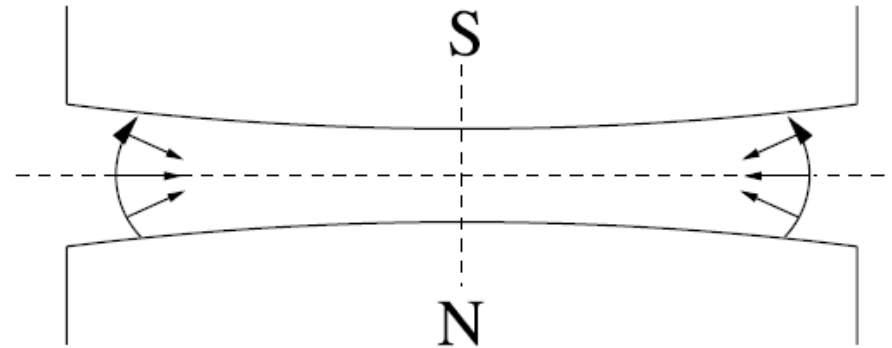

Pole shaping provides slight gradient

## Synchro cyclotrons:

Cyclotron w/ radially dependent RF frequency:  $\nu_{RF} = \frac{1}{2\pi} \frac{q}{m} \frac{B(r)}{\gamma(r)}$  ← B field correction  
← relativistic correction

→ no continuous operation:  
typical duty cycle of only 1% (modulation typ. 50 – 2000 Hz)

→ allows many turns (10000 – 50000):  
typical energies of 500 – 800 MeV (p, d, He) with moderate max. voltage (10 kV)

# PSI Ring cyclotron generates 1.4 MW proton beam at 590 MeV kinetic energy

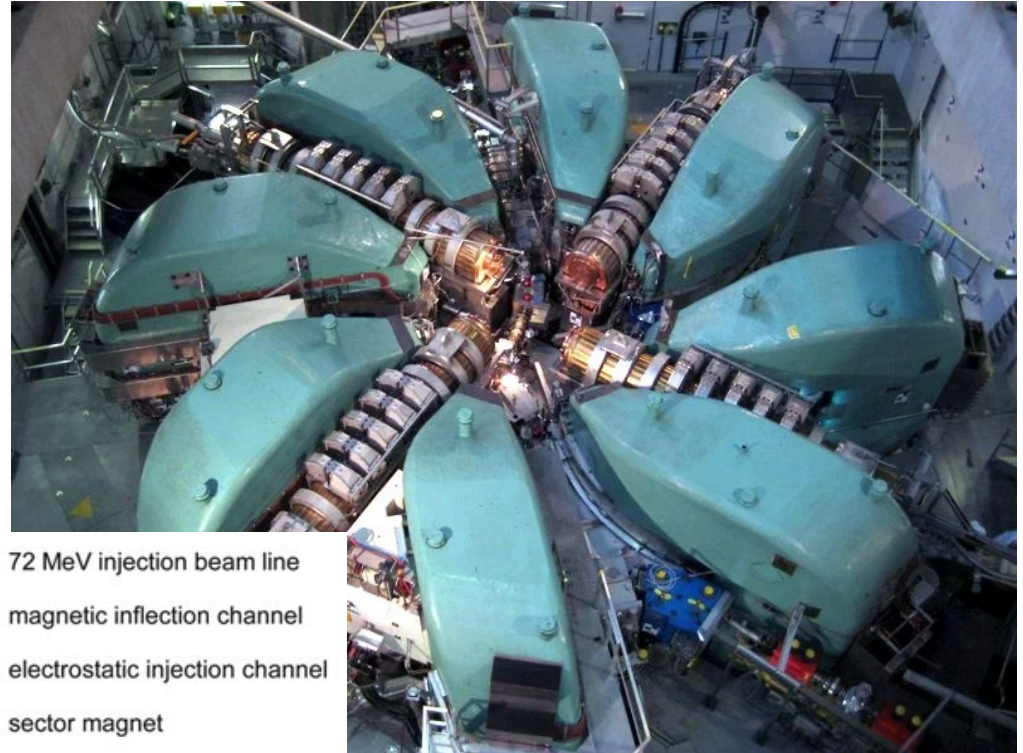
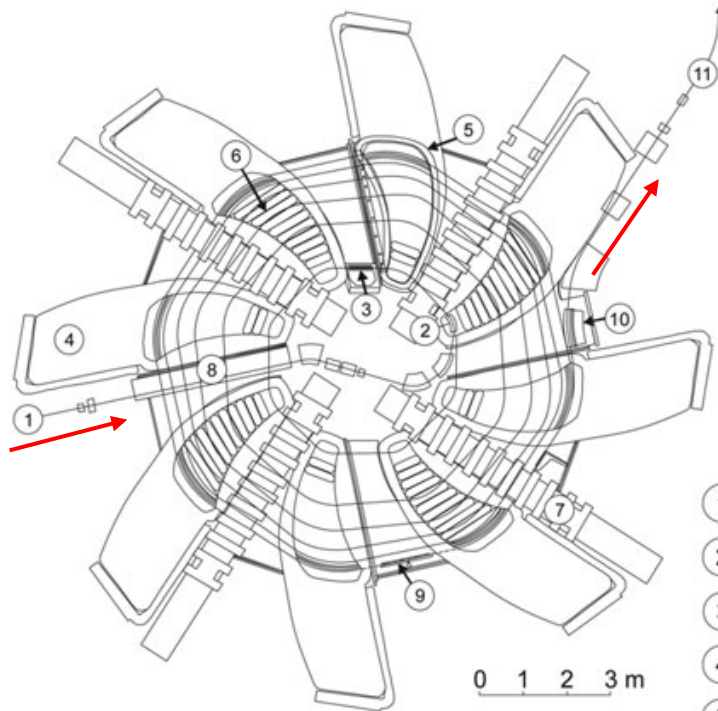

- ① 72 MeV injection beam line
- ② magnetic inflection channel
- ③ electrostatic injection channel
- ④ sector magnet
- ⑤ main coil
- ⑥ correction coils
- ⑦ 50 MHz accelerating cavities
- ⑧ 150 MHz flattop cavity
- ⑨ electrostatic extraction channel
- ⑩ septum magnet
- ⑪ 590 MeV beam line

## 5. Circular accelerators: Synchrotrons

Circular accelerator w/ B-field limited to a narrow ring area:

→ increase of R and thus the energy!

Transversal focusing using B field gradients along the ring:

→ betatron (transverse) oscillations

Ramp-up of B-field synchronously to particles momentum: **Synchrotron**

Acceleration using RF cavities

→ synchrotron (longitudinal) oscillations around  $\varphi_s$

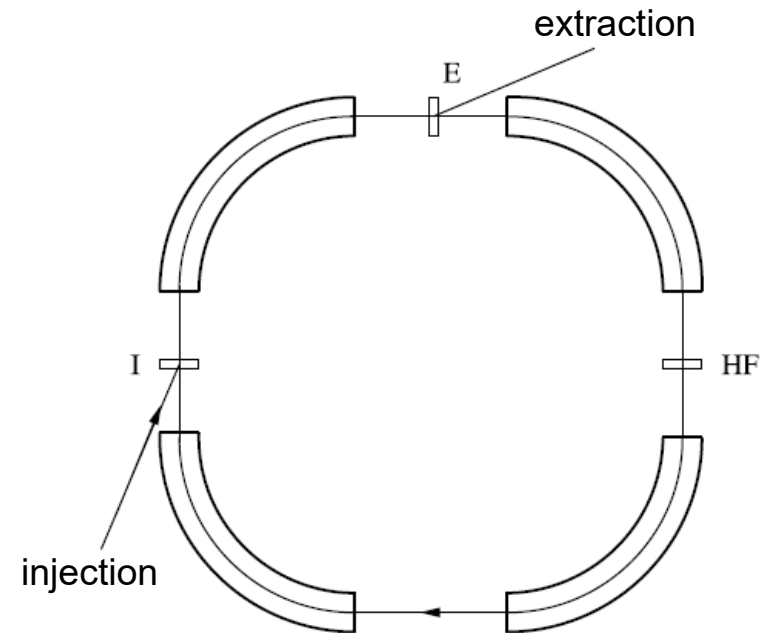

Constant gradient

Two principle types:

**Constant gradient** synchrotrons - all dipoles have the same gradient: **weak focusing**

**Alternating gradient** synchrotrons – 2 type of dipoles w/ different gradients

(**modern accelerators**) OR additional quadrupoles: **strong focusing**



## Phase stability and synchrotron oscillation

Phase focusing to keep single particles inside bunches with a finite phase widths

For synchrotrons, relation between revolution frequency and momentum is important:

$$\frac{\Delta\omega}{\omega} = \eta \frac{\Delta\rho}{\rho} \quad \left. \vphantom{\frac{\Delta\omega}{\omega}} \right\} \begin{array}{l} \eta \text{ depends} \\ \text{on particle's } \gamma \end{array}$$

$\frac{\Delta\varphi}{\varphi_s}$       **Phase focusing requires  $\eta \neq 0$**

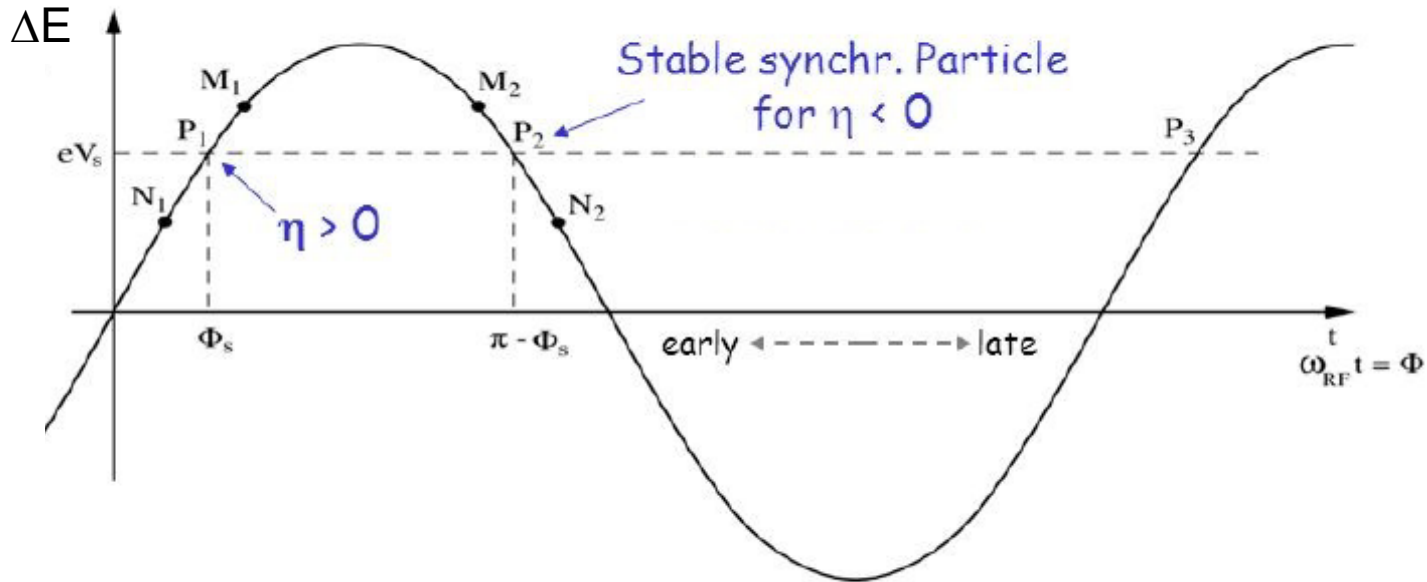

Depending on momentum

$\eta > 0$  :  $v < c$   $\rightarrow$  momentum increase leads to higher revolution frequency

$\eta < 0$  :  $v \approx c$   $\rightarrow$  momentum increase leads to longer paths and lower frequency

## Weak Focusing: Constant Gradient Synchrotrones:

Problem:

How to limit the beam in the transverse plane to reasonable aperture? (if aperture too large the dipole magnets become huge)

**Weak focusing:** see cyclotrons

Dipole magnets with radial field gradient:

$$\text{Field index: } n = - \left( \frac{\partial B}{\partial r} \right)_{r=R} \frac{R}{B}$$

For focusing in H-plane:  $n \leq 1$

For focusing in V-plane:  $n > 0$

Hence condition for double focusing

$$0 < n < 1$$

(**Kerst** and **Serber**, 1941)

Typical  $n$  chosen between 0.2 and 0.3

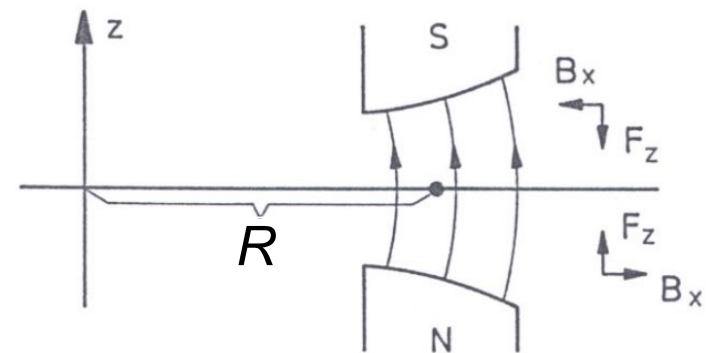
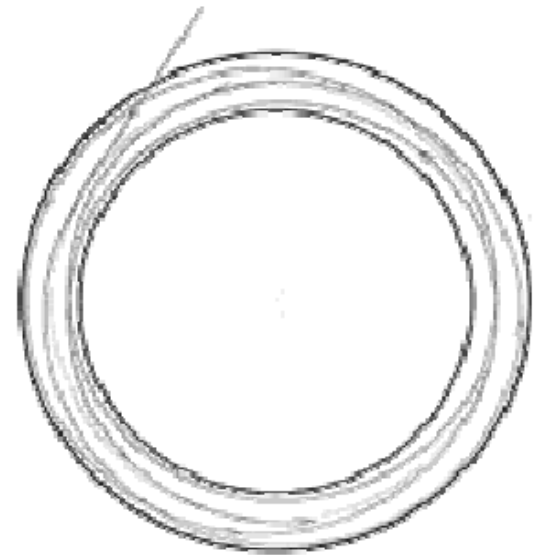

Problem: large deviations of particle in transverse plane

→ large apertures

# Cosmotron (3.3 GeV, BNL, 1953-1966): first >1 GeV proton-synchrotron

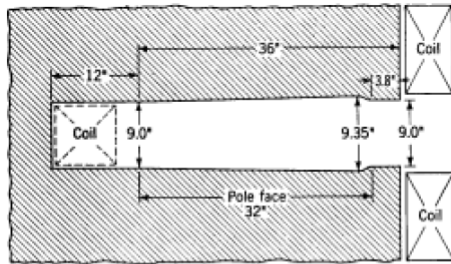

Gap aperture:  
 $0.6 \text{ m} \times 0.22 \text{ m}$

**The Cosmotron magnet**

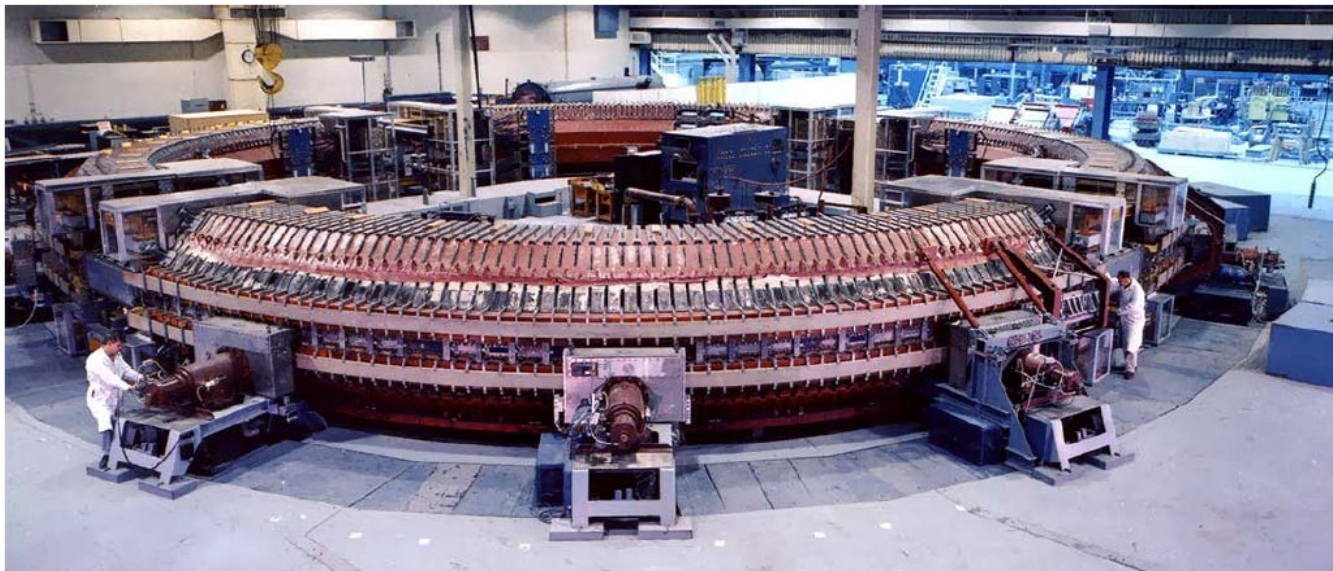
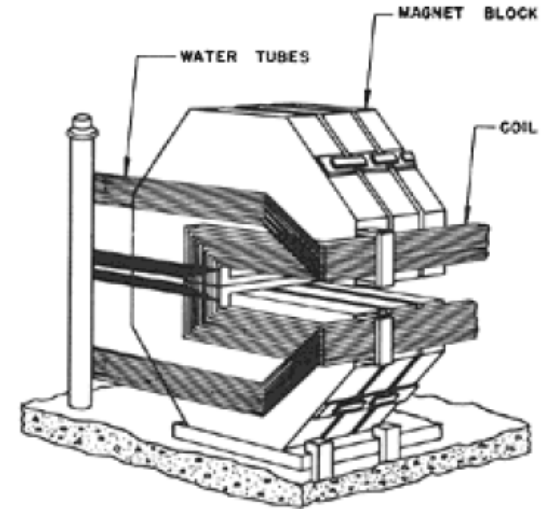

1<sup>st</sup> synchrotron providing particle beam for experiments away from accelerator.

Larger energies seemed unaffordable – magnets become too large!

## Principle of Strong Focusing (1950 Cristofilos, 1952 Courant, Livingston & Snyder)

Transverse fields defocus in one plane and focus in the other plane. But two successive elements, one focusing the other defocusing, can focus in both planes:

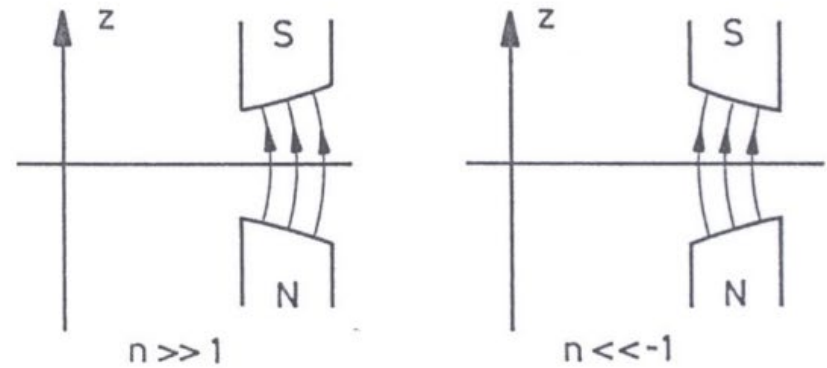
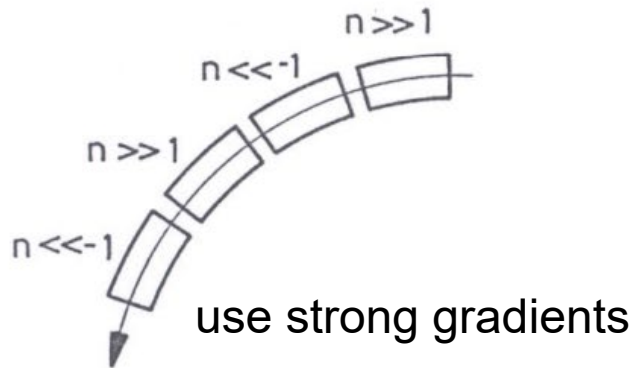

Optics:

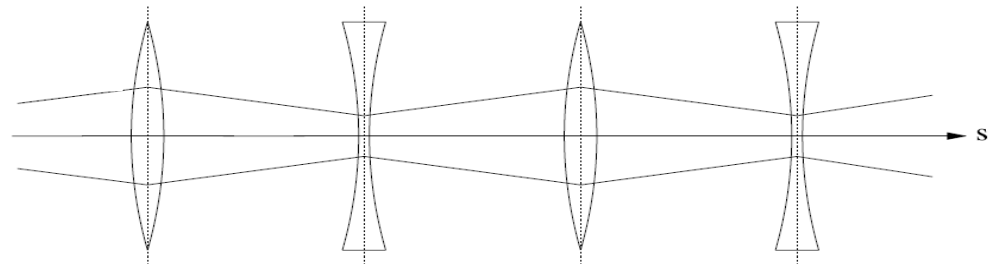

Condition: large field gradient  $|n| \gg 1$  (typ.  $\approx 20$ ) - strong alternating gradients.

1<sup>st</sup> machine: 1959, CERN PS (Proton Synchrotron), 28.3 GeV, still in use. (C=628m)

2<sup>nd</sup> machine: 1960, AGS (BNL), 33 GeV, still in use. (C=810 m)

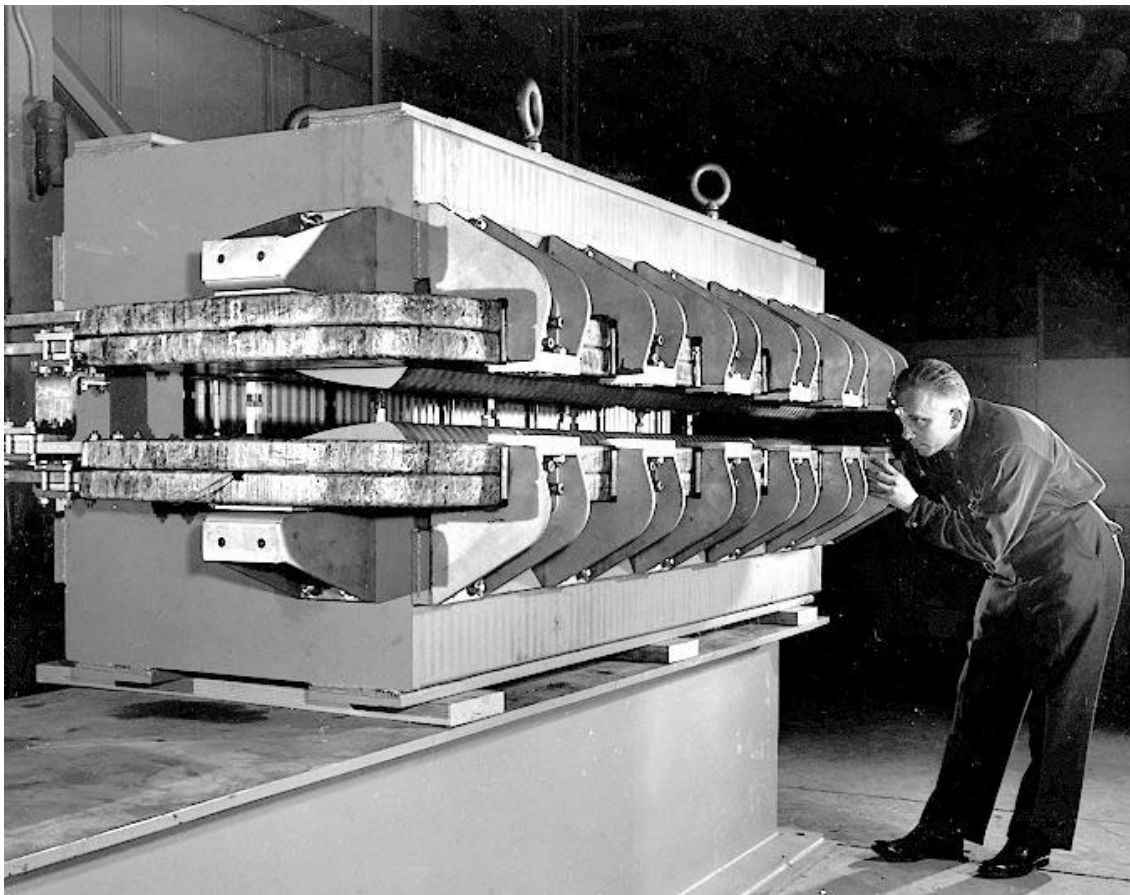

AGS magnet  
(PS magnets similar)

2<sup>nd</sup> type with different pole  
orientation

Special pole form to  
create large gradient.

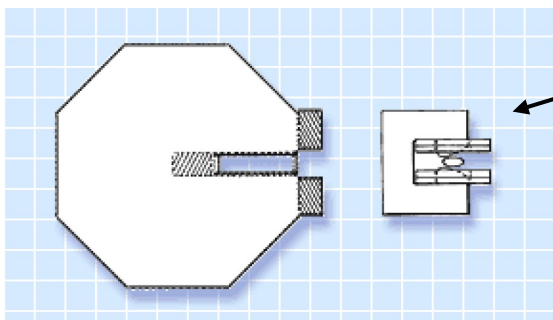

Comparison: Cosmotron and AGS magnet

AGS and PS magnets are called combined  
function magnets (dipole & focusing).

# Quadrupoles and FODO cells

Magnetic quadrupoles focus in one plane and defocus in the other plane.

## FODO cells:

Focusing and Defocusing quadrupoles are alternated and interleaved with bending dipole magnets.

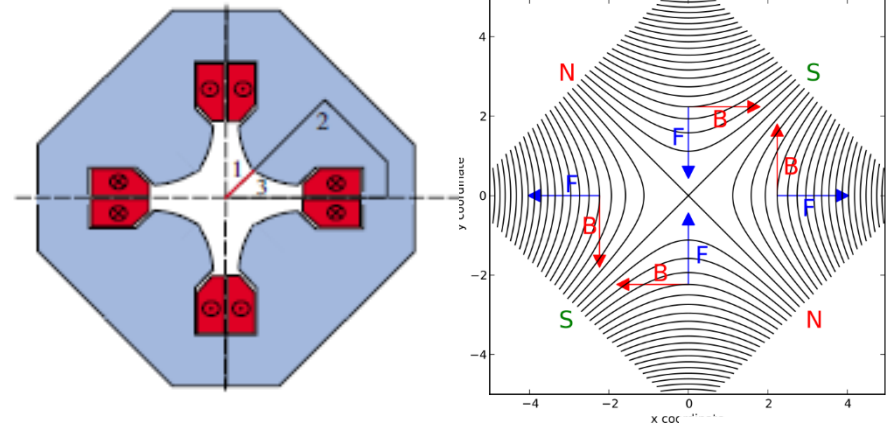
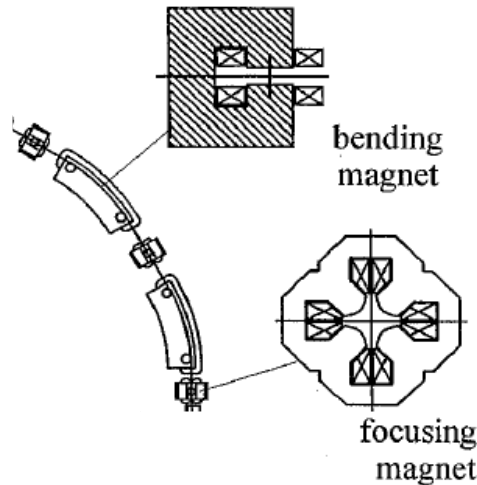

Important:  $F_x \sim \Delta x$

## Beam envelope

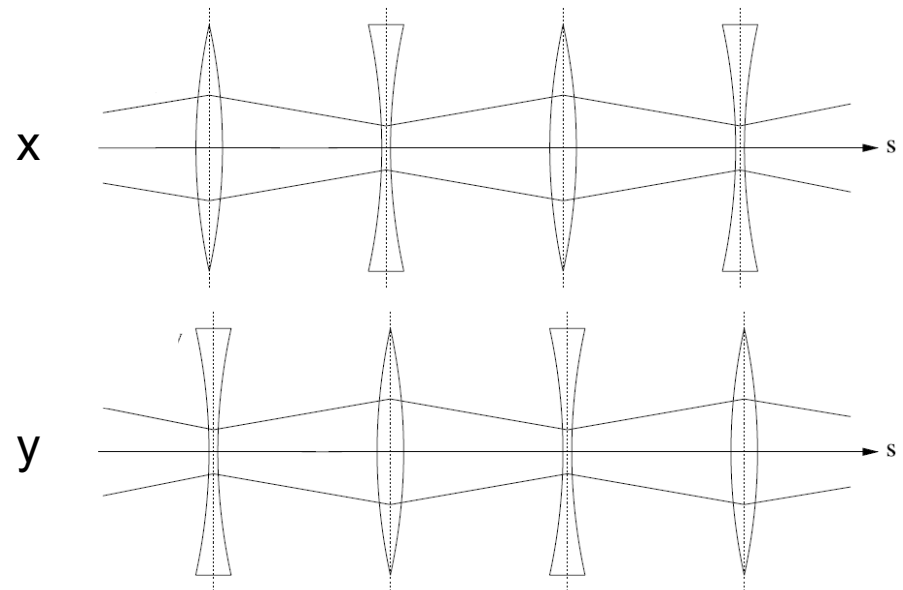

Modern accelerators consist of FODO cells.

## 6. Beam optics and particle tracing

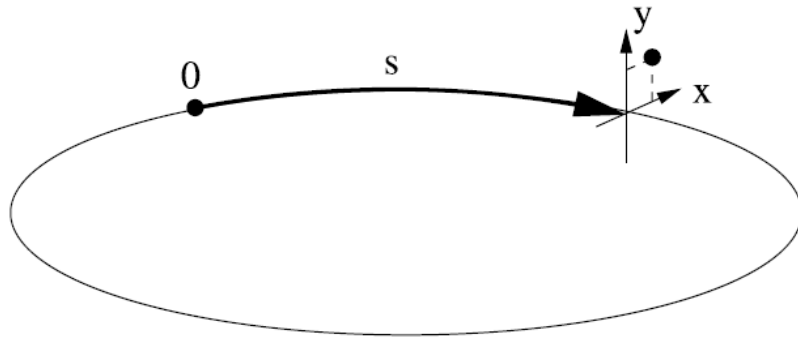

Linear beam optical elements

Dipole field:

$$B_y(x) = \frac{C}{R} = \text{const.}$$

Quadrupole:

$$B_y(x) = kx$$

Particle track inside quadrupole:  
(dipole field)

Solution w/ initial  
conditions  $x_0$  and  $x'_0$

$$x''(s) - kx(s) = 0 \quad \text{for } k < 0 \text{ (focusing)}$$

$$x(s) = x_0 \cos \sqrt{|k|}s + \frac{x'_0}{\sqrt{|k|}} \sin \sqrt{|k|}s$$

$$x'(s) = -x_0 \sqrt{|k|} \sin \sqrt{|k|}s + x'_0 \cos \sqrt{|k|}s$$

Using matrix description:

$$\Omega = \sqrt{|k|}s$$

$$\begin{pmatrix} x(s) \\ x'(s) \end{pmatrix} = \begin{pmatrix} \cos \Omega & \frac{1}{\sqrt{|k|}} \sinh \Omega \\ -\sqrt{|k|} \sinh \Omega & \cosh \Omega \end{pmatrix} \begin{pmatrix} x_0 \\ x'_0 \end{pmatrix}$$

General quadrupole transfer matrix:

$$\mathbf{M} = \left\{ \begin{array}{l} \begin{pmatrix} \cos \Omega & \frac{1}{\sqrt{|k|}} \sinh \Omega \\ -\sqrt{|k|} \sinh \Omega & \cosh \Omega \end{pmatrix} \\ \begin{pmatrix} 1 & \mathbf{S} \\ 0 & 1 \end{pmatrix} \\ \begin{pmatrix} \cosh \Omega & \frac{1}{\sqrt{k}} \sinh \Omega \\ \sqrt{k} \sinh \Omega & \cosh \Omega \end{pmatrix} \end{array} \right. \begin{array}{l} k < 0 \\ \text{(focusing)} \\ \\ k = 0 \\ \text{drift} \\ \\ k > 0 \\ \text{(defocusing)} \end{array}$$

Dipole transfer matrix:  
(no gradient)

$$\mathbf{M} = \begin{pmatrix} \cos \frac{S}{R} & R \sin \frac{S}{R} \\ -\frac{1}{R} \sin \frac{S}{R} & \cos \frac{S}{R} \end{pmatrix}$$

For several linear (drift, dipole, quadrupole) optical elements transfer matrix is the product of the single optical components  
 → allows ray-tracing for particle w/ different initial conditions  $x_0, x_0'$



## 7. Transverse beam dynamics: betatron oscillation

Ray-tracing allows to calculate the orbit for given particle, however does not tell much about the collective properties of the beam.

“effective dynamics”:

$$x''(s) - kx(s) = 0$$

Transverse orbit function  $x(s)$  describes an oscillation around the ideal orbit with an amplitude and a phase which depend on the position  $s$  of the orbit.

Ansatz for betatron oscillation to solve the differential equation:

$$x(s) = Au(s)\cos(\psi(s) + \phi)$$

Constants  $A$  and  $\phi$  are integration constants

Using this ansatz one obtains a non linear equation for  $u(s)$  which can be solved only numerically. Matrix method allows to consider the complete beam optics and allow to determine the so called  $\beta$  function (method not discussed):

with  $\beta(s) = u^2(s)$  and emittance  $\sqrt{\varepsilon} = A$

$$x(s) = \sqrt{\varepsilon} \sqrt{\beta(s)} \cos(\psi(s) + \phi)$$

# Betatron oscillation

The particles perform inside the synchrotrons magnet structure betatron oscillation which are described by a location  $s$  dependent amplitude  $E(s)$ :

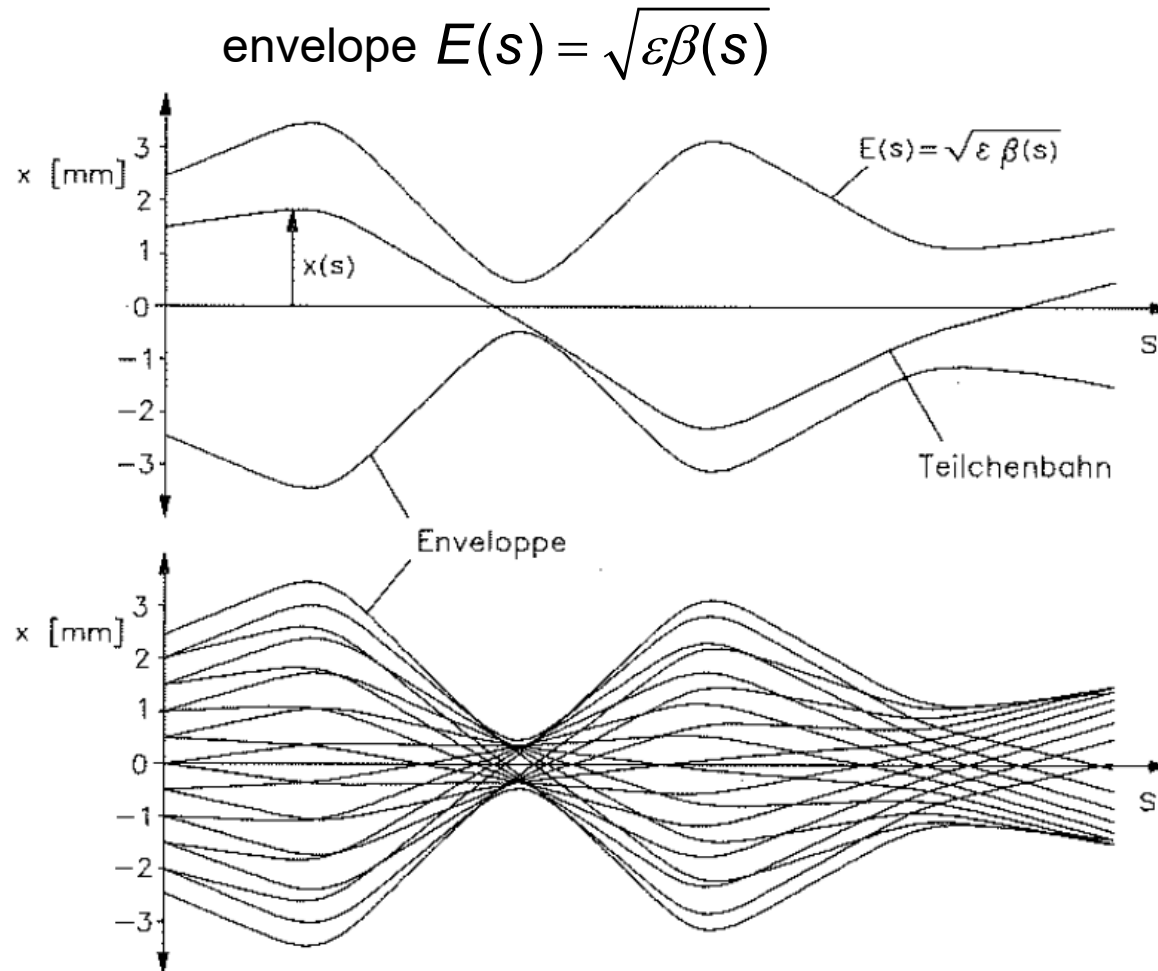

# Phase ellipse and Liouville theorem

General form of orbit equations in phase space:

$$x(s) = \sqrt{\varepsilon} \sqrt{\beta(s)} \cos(\psi(s) + \phi)$$

$$x'(s) = -\frac{\sqrt{\varepsilon}}{\sqrt{\beta(s)}} \left[ \alpha(s) \cos(\psi(s) + \phi) + \sin(\psi(s) + \phi) \right]$$

$$\alpha(s) \equiv -\frac{\beta'(s)}{2}$$

Parametric representation of an ellipse in  $(x, x')$  space: can be seen by eliminating the  $(\psi(s)+\phi)$  dependence, e.g.:

$$\cos(\psi(s) + \phi) = \frac{x(s)}{\sqrt{\varepsilon} \sqrt{\beta(s)}}$$

Coordinate representation:

$$\frac{x^2}{\beta} + \frac{(\alpha x + \beta x')^2}{\beta} = \varepsilon$$

or with

$$\gamma \equiv \frac{1 + \alpha^2}{\beta}$$

$$\gamma x^2 + 2\alpha x x' + \beta x'^2 = \varepsilon$$

Ellipse with an area of  $\pi\varepsilon$

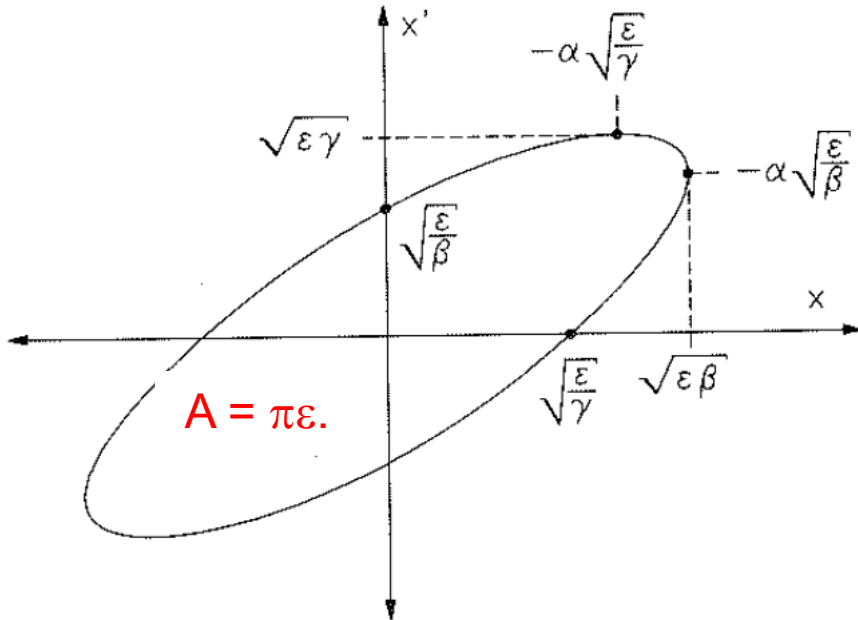

### Liouville theorem:

Occupied phase space element stays constant when particle follow canonical equations of motion.

Phase space ellipse can be rotated or deformed when particles travel along the beam line or if they are focused but the area stays constant!

### Significance of emittance:

Up to  $\pi$  equal to phase space area:

$$A = \pi\epsilon.$$

Emittance often given as  $\pi\epsilon$  [rad m].

e.g. LHC:  $\pi\epsilon = 1.68 \times 10^{-9}$  rad m

$\epsilon$  defined by particle injection.

$\epsilon$  and  $\beta(s)$  important for luminosity

Particles have no sharp boundaries.  
Assume Gaussian distribution in x:

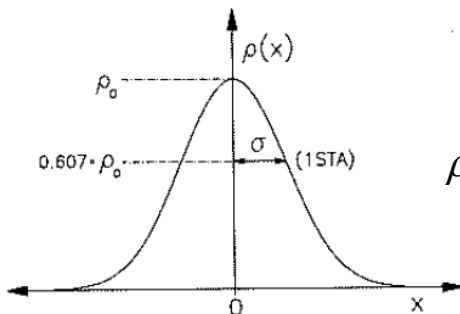

$$\rho(x) = \frac{N}{2\pi\sigma_x} \exp\left(-\frac{x^2}{2\sigma_x^2}\right)$$

Define emittance  $\epsilon$  as  $1\sigma$  contour:

$$\sigma_x(s) = \sqrt{\epsilon\beta_x(s)}$$

# 8. Synchrotron Radiation

$$\Theta_{\text{rms}} = \frac{1}{\gamma}$$

Due to the angular acceleration charged particles (**electrons**) in a synchrotron emit bremsstrahlung: synchrotron radiation



Classical electromagnetic theory gives power loss for a relativistic electron:

$$P_{\text{rad}} = \frac{c C_{\text{rad}}}{2\pi} \frac{E_{\text{Beam}}^4}{R^2} \quad \text{with} \quad C_{\text{rad}} = \frac{e^2}{3\epsilon_0 (m_e c^2)^4} = 8.85 \cdot 10^{-5} \text{ m GeV}^{-3}$$

$E_{\text{beam}}$  = energy of beam  
 $R$  = nominal radius

$e$  = elementary charge     $m_e$  = mass  
 $\epsilon_0$  = electrical field const.

$$\gamma = \frac{E_{\text{Beam}}}{m_e c^2}$$

Energy loss per turn:

$$E_{\text{rad}} = \oint P_{\text{rad}} dt = C_{\text{rad}} E^4 \frac{1}{2\pi} \oint \frac{ds}{R^2} \quad \longrightarrow \quad \text{For nominal particle on nominal orbit}$$

$$E_{\text{rad},0} = C_{\text{rad}} \frac{E^4}{R_0} \sim \frac{\gamma^4}{R_0}$$

$$E_{\text{rad},0} = \frac{4\pi}{3} \alpha \frac{\gamma^4}{R_0}$$

(natural units)

**Positive:** emission of synchrotron radiation leads to damping of betatron and synchrotron oscillations.

# Radiation spectrum

$$\frac{dP_{rad}}{d\omega} = \frac{P_{rad}}{\omega_c} S\left(\frac{\omega}{\omega_c}\right) \quad \text{with} \quad \omega_c = \frac{3c\gamma^3}{2R}$$

Spectral function  $S\left(\frac{\omega}{\omega_c}\right)$   $\longrightarrow$

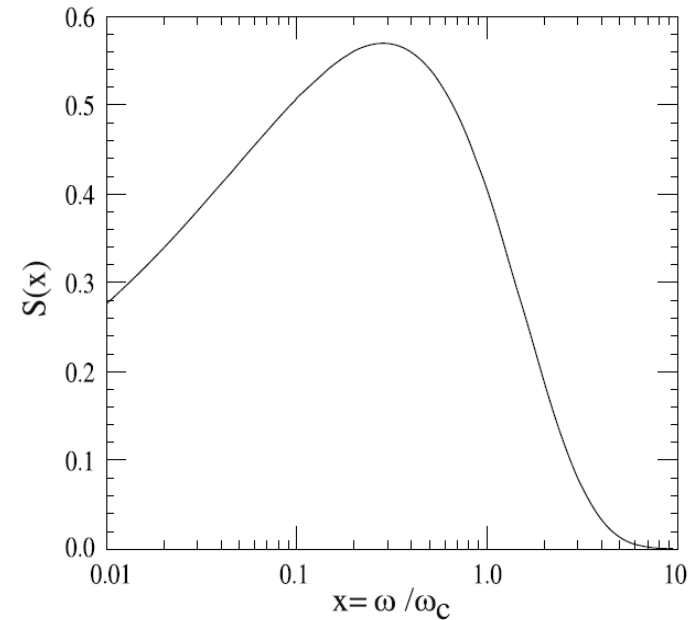

Major fraction emitted around  $\omega_c$  with  $\langle \hbar\omega \rangle = \frac{8}{15\sqrt{3}} \hbar\omega_c$

$$\Theta_{rms} = \frac{1}{\gamma}$$

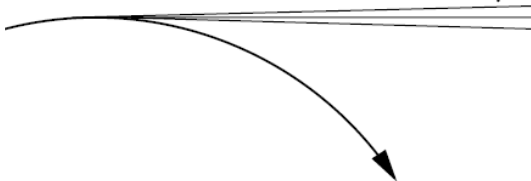

Effect of relativistic kinematics:  
w/ increasing electron energy  
photons are boosted forward

$$\theta_{RMS} = \frac{1}{\gamma}$$

Example:  
e-beam @ 3.5 GeV  
w/  $R_0 = 13.3$  m,  $I_e = 1$  A

$$E_{rad,0} = 1 \text{ MeV}$$

$$P_{rad} = 1 \text{ MW}$$

$$\omega_c = 1.2 \cdot 10^{19} \text{ s}^{-1}$$

$$\hbar\omega_c = 7.7 \text{ keV}$$

Synchrotron is also emitted in focusing magnets and other beam optic elements.

# 9. Colliders and luminosity

To achieve maximum CMS energies collider experiments are preferred over fix target configurations.

2 separate synchrotrons:

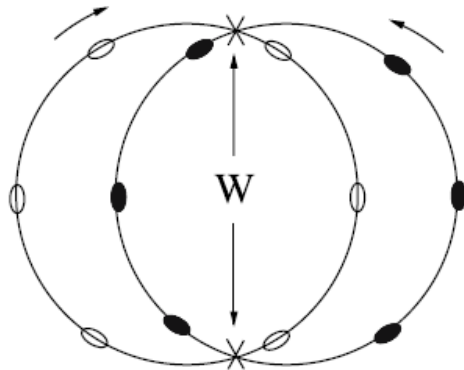

Same particles (pp, AA) require two separate rings: e.g. LHC (A = (heavy) ions: e.g. Au, Pb)

single synchrotrons:

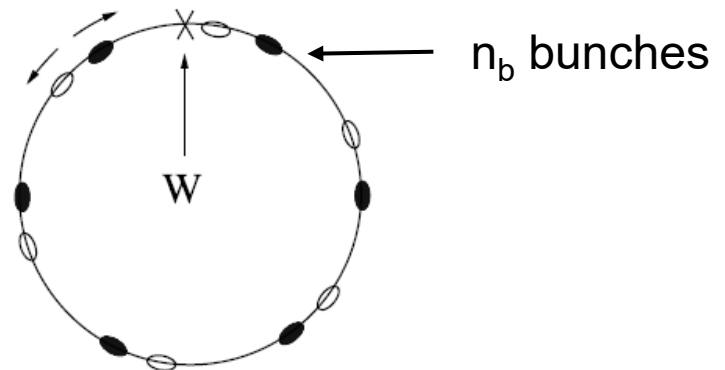

Particles and anti-particles can be stored and accelerated in one ring ( $p\bar{p}$ ,  $e^+e^-$ ): LEP ( $e^+e^-$ ), Sp $\bar{p}$ S + Tevatron ( $p\bar{p}$ )

# Luminosity

Original luminosity definition:  
Extracted beam on fixed target.

$$\mathcal{L} = \dot{N}_B \frac{N_T}{A}$$

$$\left[ \begin{array}{l} \dot{N}_B \text{ beam particle s}^{-1} \\ A \text{ area, } N_T = \text{numb. targets} \\ \frac{N_T}{A} \text{ target area density} \end{array} \right.$$

Collider w/ two beams:

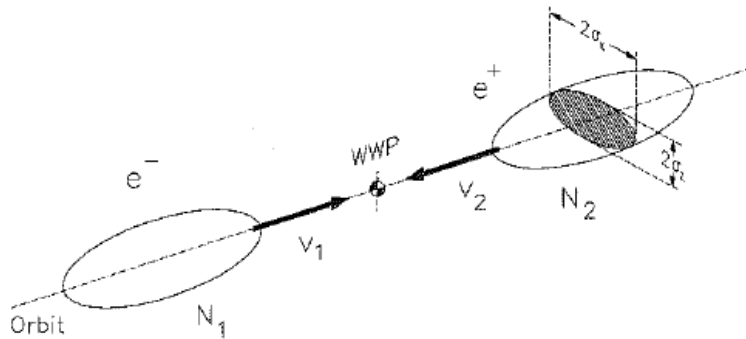

$$\dot{N}_B = f \cdot n_b N_1$$

$$\left[ \begin{array}{l} f \text{ revolution frequency} \\ n_b \text{ number of bunches} \\ N_1 \text{ particles per bunch} \end{array} \right.$$

$$\mathcal{L} = f \cdot n_b \frac{N_1 N_2}{A_{\text{eff}}}$$

$A_{\text{eff}}$  = effective interaction area

For a beam Gaussian beam profile:

$$A_{\text{eff}} = 4\pi\sigma_x\sigma_y$$

$$\mathcal{L} = f \cdot n_b \frac{N_1 N_2}{4\pi\sigma_x\sigma_y}$$

Reminder: The Gaussian width is given by the emittance and the betatron value  $\beta$  at the IA point ( $\beta^*$ ):

$$\sigma_{x,y} = \sqrt{\epsilon\beta_{x,y}^*}$$



# Example: Large Hadron Collider pp:

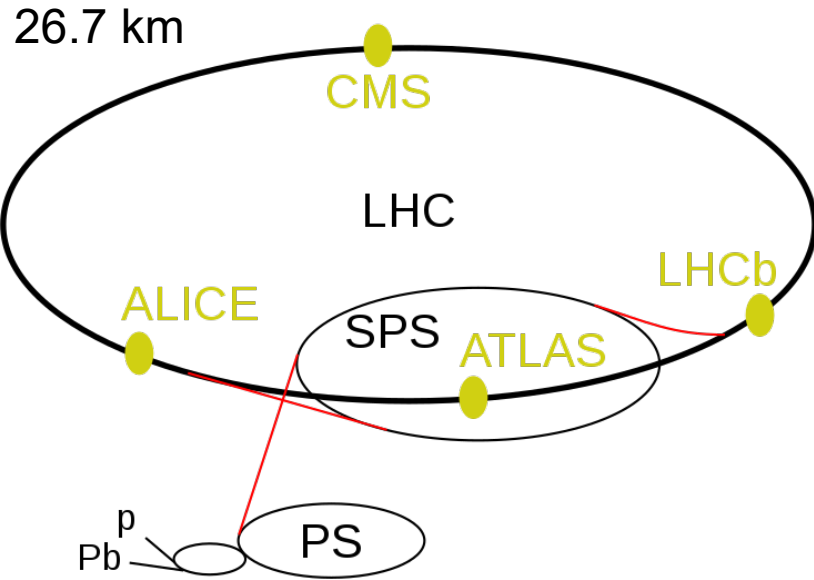

## Beam parameters:

$C = 26659 \text{ m}$   
 $n_b = 2808 / \text{beam}$   
 $N_b = 1,15 \cdot 10^{11}$   
 $I_B = 0,54 \text{ A / beam}$   
 $\pi\epsilon = 1.68 \times 10^{-9} \text{ rad m}$   
 $\beta^* = 0.55 (0.33) \text{ m}$   
 $L = 10^{34} \text{ cm}^{-2} \text{ s}^{-1}$

## RF Cavities: 8 per beam

400.8 MHz  
2 MV per cavity (5 MV/m field)  
→ 16 MV in total

8 arcs (octants, 2450 m): **23 arc cells (FODO)**

FODO: 2 Quadrupoles + 6 dipoles + multipoles

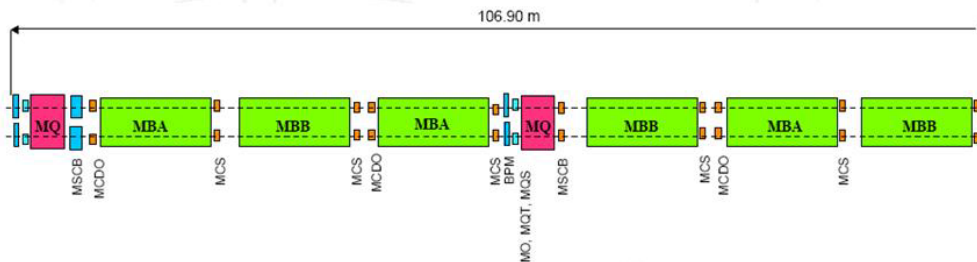

## 1232 dipoles:

$I = 11800 \text{ A}$   
 $B = 8.33 \text{ T}$   
 $R = 2804 \text{ m}$   
 $L = 14.3 \text{ m}$

Stored energy:  
7 MJ / dipole

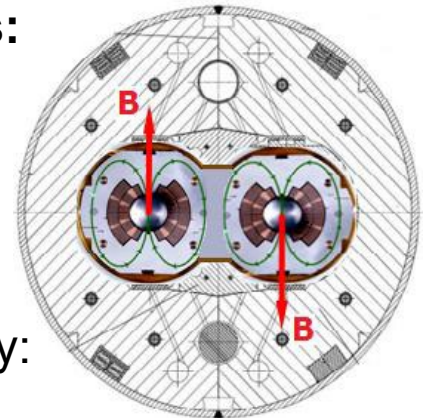

# Dipole cross section:

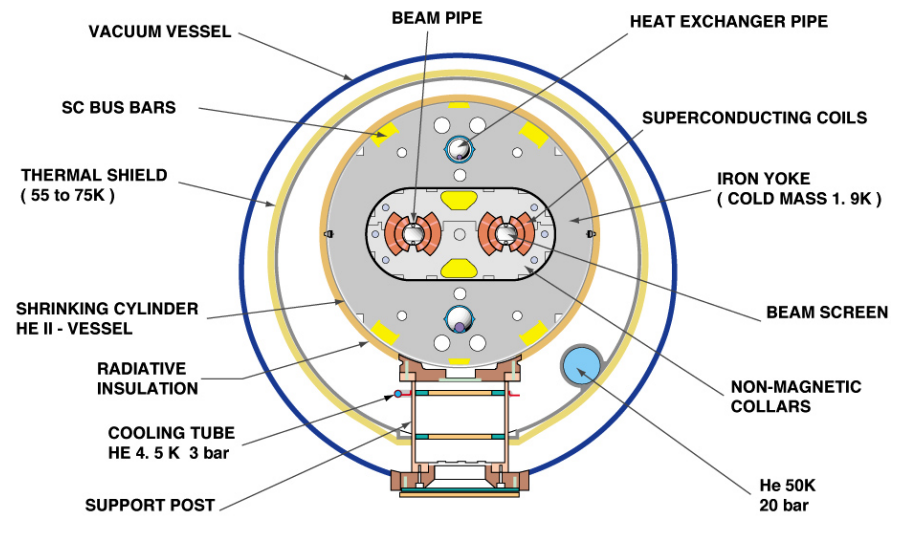

# LHC tunnel:



# PROTON PHYSICS: STABLE BEAMS

Energy:

6800 GeV

I B1:

1.30e+14

I B2:

1.36e+14

Beta\* IP1:

0.33 m

Beta\* IP2:

10.00 m

Beta\* IP5:

0.33 m

Beta\* IP8:

2.00 m

Inst. Lumi [(ub.s)<sup>-1</sup>]

IP1: 8655.95

IP2: 8.81

IP5: 5639.32

IP8: 209.76

FBCT Intensity and Beam Energy

Updated: 20:52:08

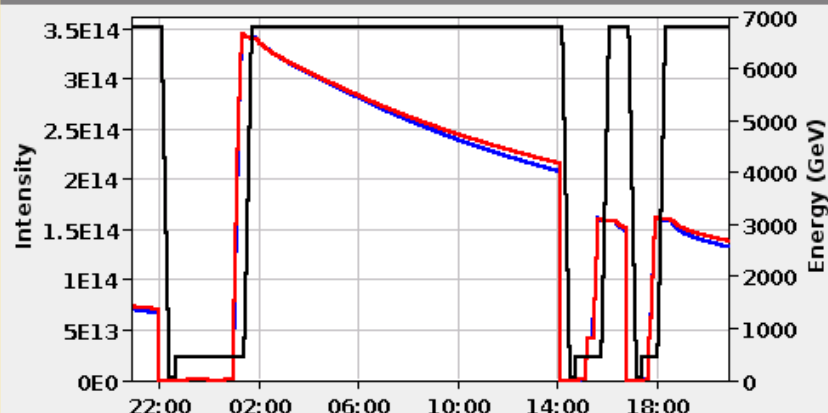

Instantaneous Luminosity

Updated: 20:52:11



## Comments (25-Oct-2022 19:36:52)

STABLE BEAMS fill 1200b VELO insertion  
 IP1 B\* lev mu=54, IP5 sep lev mu=35  
 IP2 and IP8 sep lev, XRP IN  
 End of fill scraping test  
 Plan to dump ~21:30, then physics 2400b  
 Wednesday access from 8am to 4pm

## BIS status and SMP flags

	B1	B2
Link Status of Beam Permits	true	true
Global Beam Permit	true	true
Setup Beam	false	false
Beam Presence	true	true
Moveable Devices Allowed In	true	true
Stable Beams	true	true

AFS: 25ns\_1167b\_1154\_1022\_1088\_144bpi\_12inj\_3INDIV PM Status B1

ENABLED

PM Status B2

ENABLED

# 10. Limits for future high-energy colliders

Proton-Proton synchrotron:

Limitation:  $p = 0.3BR$

B field strength of dipole magnets:  
LHC magnets  $B \approx 8.3 \text{ T} \rightarrow$  future:  $\sim 16 \text{ T}$

Ring radius:  
 $2\pi R_{\text{LHC}} = 26.7 \text{ km} \rightarrow$  future:  $\sim 100 \text{ (91) km}$

FCC  
= Future circular collider

100 TeV (CMS energy) machine:  
Requires 4 time more magnets w/ double field strength

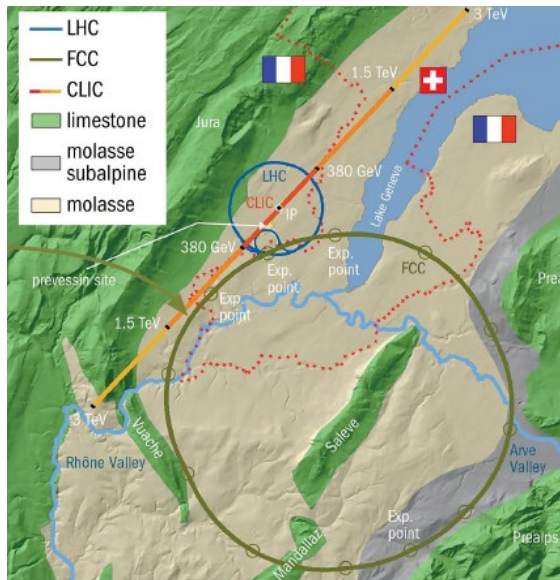

W/ new super  
conducting  
magnets

whole wire critical current density [ $\text{A}/\text{mm}^2$ , 4.2 K]

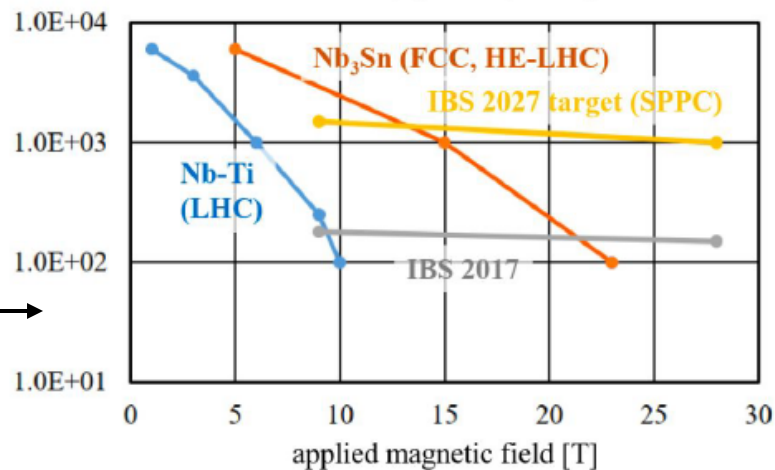

**Electron-positron colliders:**  $\sqrt{s} = 2E_{beam} = \sqrt{s_{IA}}$  (point like electrons collide)

Physics processes require in general smaller beam energy than pp colliders.

**Synchrotrons:** Beam energy limited by synchrotron radiation

**Limitation:**  $E_{rad} = C_{rad} \frac{E^4}{R} \sim \frac{\gamma^4}{R} \implies$  Huge electrical power needed to compensate synchrotron loss.

Design study: FCC-ee w/  $2\pi R \sim 100$  km and  $\sqrt{s} = 350$  GeV  
Synchrotron power loss per beam: 50 MW

**Linear collider:** Beam energy limited by accelerating structure

ILC Design study:

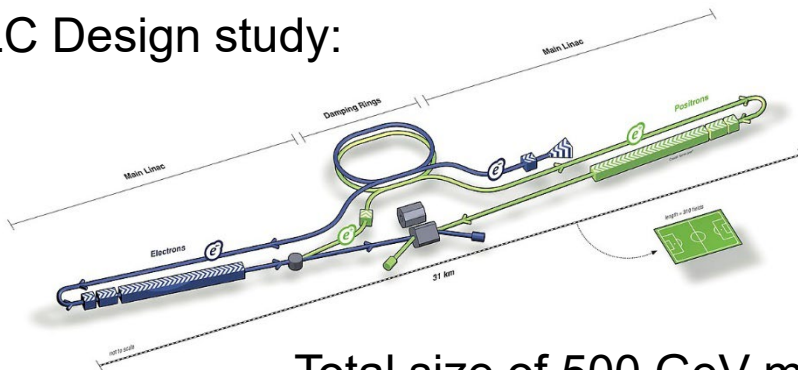

Maximal achievable field gradient in accelerating cavities:  $\sim 35$  MV/m

$\sqrt{s} = 500$  GeV (250 GeV / beam):  
 $\rightarrow 2 \times 7.2$  km of accelerating cavities

Total size of 500 GeV machine  $\sim 30$  km, total AC power 250 MW

New concept for acceleration: **plasma acceleration**  $\rightarrow$  gradients of up to GV/m<sup>37</sup>