

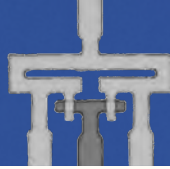

5. Superconducting Qubits

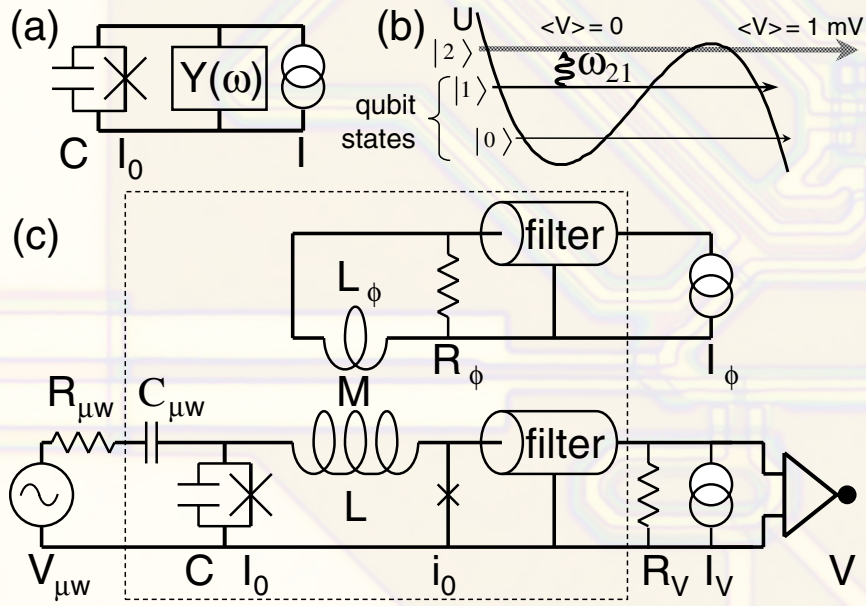

First observation of Rabi oscillations in phase qubit 2002

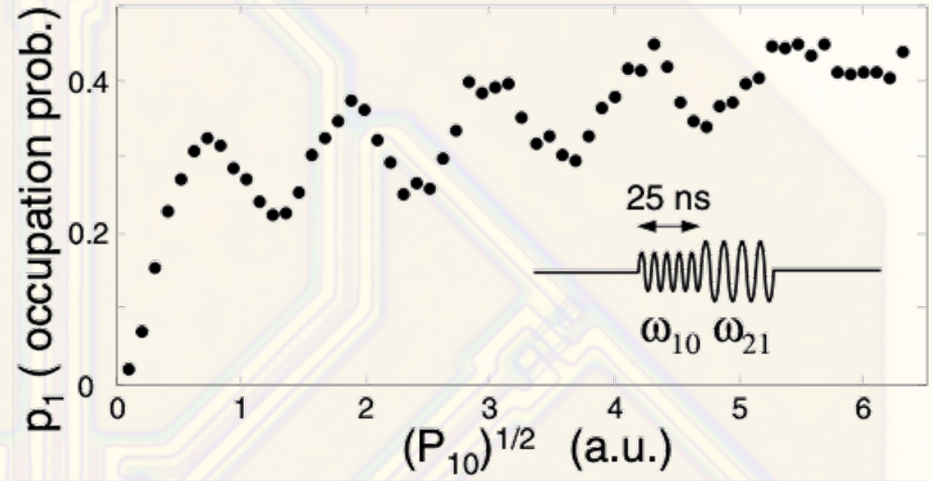



5. Superconducting Qubits

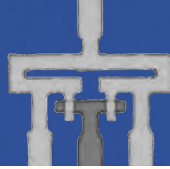

First observation of Rabi oscillations in phase qubit

